

OMCN
S.p.A.



**3000
3500 KG**



ART. 705

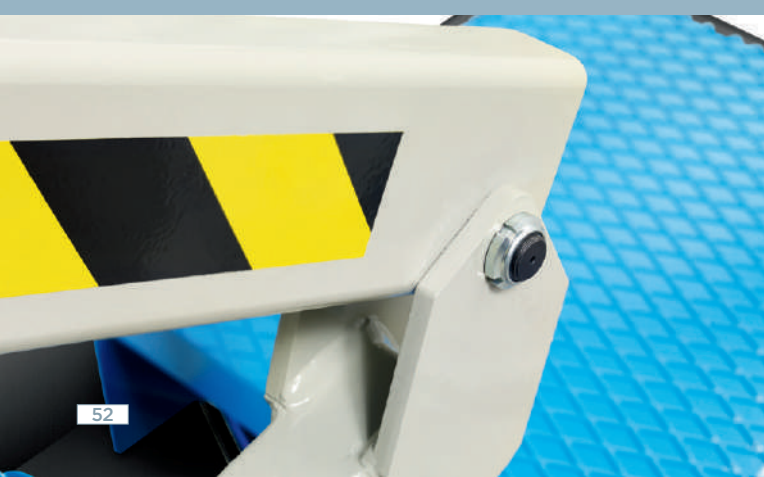

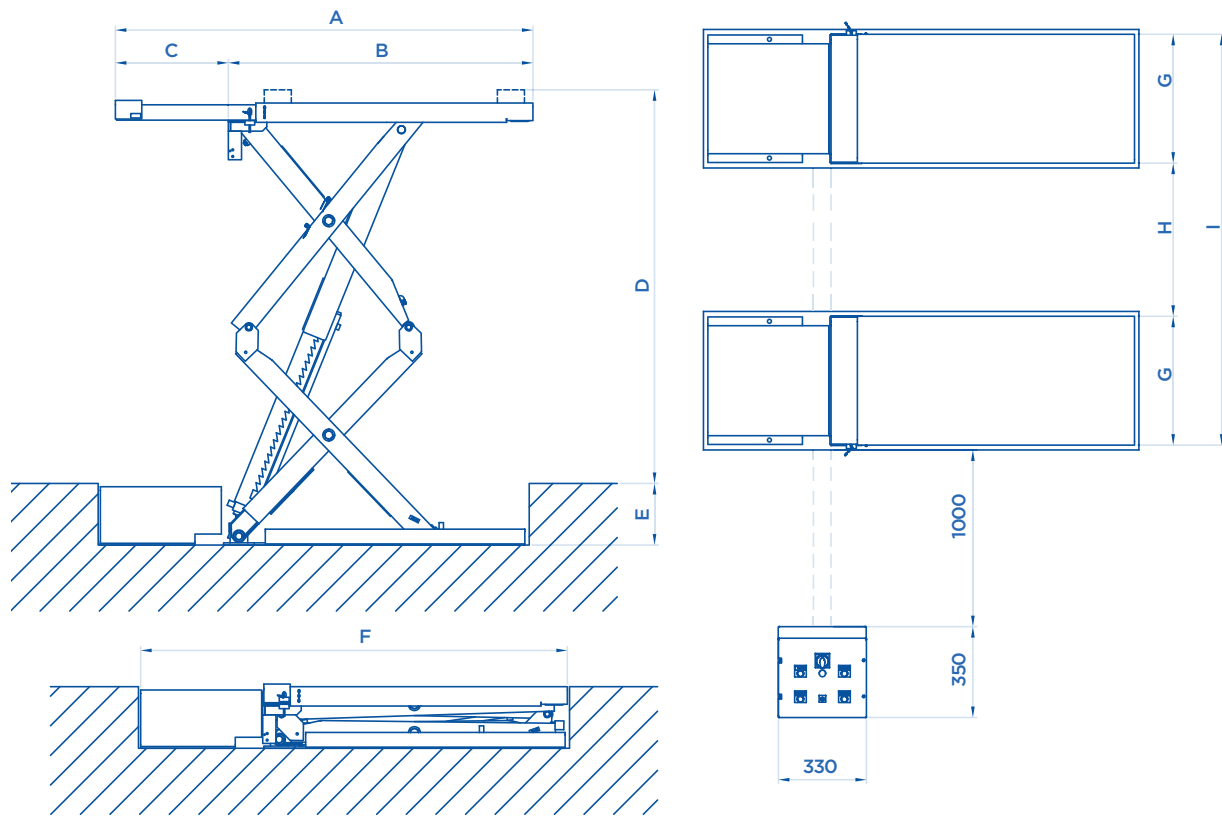

OPTIONAL Pag. 064

ART.			Motore trifase Three-phase motor Moteur triphasé Netzspannung	A	B	C	D	E	F	G	H	I	
				mm	mm	mm	mm	mm	mm	mm	mm	mm	KG
703	3000 Kg	3,3 KW	400V • 50HZ	1755	1385	370	1800	270	1785	520	800	1840	910
703/A	3000 Kg	3,3 KW	400V • 50HZ	1900	1385	515	1800	270	1955	520	800	1840	950
705	3500 Kg	3,3 KW	400V • 50HZ	1900	1385	515	1800	280	1955	590	800	1980	1000
705/M	3500 Kg	3,3 KW	400V • 50HZ	2100	1585	515	1800	280	2155	590	800	1980	1050

Potenza motore • Motor power
Puisissance moteur • Motorleistung